

## LIQUID E-SIGHT - Liquid/Explosive Trace Detection

### ■ Overview

The Liquid E-Sight is X-ray liquid detection system which is capable of detecting and differentiating the difference between Safe, Suspect and Dangerous types of liquid. The Liquid E-Sight has high speed detecting capabilities, providing results to the operator in 20seconds or less whilst maintaining a high through-put for all scales of operations. The Liquid E-Sight is capable for detecting liquids in glass, plastic, metal, ceramics and other normal packagaing material.

- **Object Size: 150mm (D) x 250mm (H)**
- **Dimensions: 1050mm (L) x 720 mm (W)x 1205 mm (H)**

### ■ Features

- Detects liquid in glass, plastic, metal, ceramics and more..
- High speed detection in 20 seconds or less per liquid object
- Wheel with lock, for easy moving and fixing
- Video image and CT image of detected object for analysing and tracing
- Power on / running self-diagnostics function
- Detects and differentiates water, milk, alcohol, gas, lacquer thinner, sulphuric acid and other liquids with their danger levels of: Safe , Suspect and Danger

### ■ Specifications

- **Object Size: 150mm (D) x 250mm (H)**
- **Detecting Speed: 180 pc/Hour**
- **X-ray Generator: 80KV Combination**
- **Cooling/Duty cycle: Sealed oil cooling 100%**
- **System Noise: <60dB (A)**
- **Beam direction: Horizontal irradiation**
- **Power Consumption: About 0.50 (KVA)**
- **Size / Weight: 1050mm (L) x 720mm (W) x 1205mm (H) / 350KG**
- **Working Temperature / Humidity: 0C ~ + 45C / 20% ~ 95% (None-condensing)**
- **Storage Temperature / Humidity: 40C ~ + 60C / 20% ~ 95% (None-condensing)**
- **Power Supply: AC 220 V (+10% ~ -15%) 50+3(Hz)**

### ■ Technical Drawing

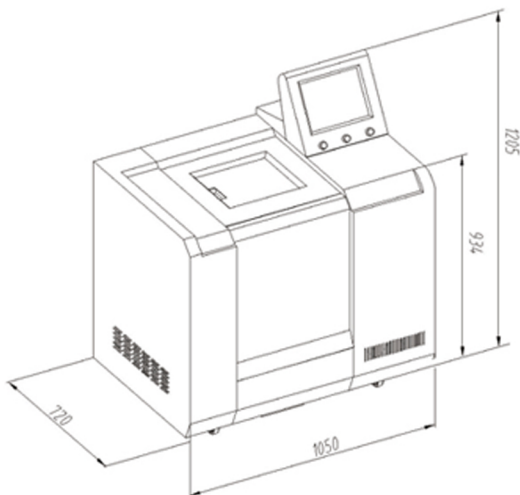

### ■ CONTACT US

- @ [info@akkula.co.uk](mailto:info@akkula.co.uk)
- 📞 Akkula Group
- ☎ +44 (0) 117 318 0845 - UK
- ☎ +1 (702) 509 - 7610 - Americas

### Follow us on Social Media

