

## 6040 CHECKPOINT - Multi Energy X-ray Security Inspection Equipment

### ■ Overview

The 6040 CORPORATE Multi Energy X-ray Security Inspection system is an intelligent safety inspection system which is able to detect Organic, Non-Organic, Mixtures and Light metals whilst maintaining a reasonable user friendly design to maintain a highly efficient operation

- **Tunnel Size: 615mm (W) x 415mm (H)**
- **Dimensions: 2300mm (L) x 910 mm (W) x 1320 mm (H)**

### ■ Features

- **Multi-Energy penetration system**
- **New x-ray protection technology**
- **Multi-functions image processing system**
- **EI-TIP( Threat Image Projection) function**
- **Collects high-speed parallel of detection data**
- **Sophisticated design with multi-functions operator interface**
- **Support JPG & BMP image transformation format to USB**



### ■ Specifications

- **Tunnel Size: 615mm (W) x 415mm (H)**
- **Conveyor Height: 681mm**
- **Conveyor Speed: 0.2m/s**
- **Max Load: 100kg ( Evenly distributed)**
- **System Noise: <65dB (A)**
- **Image Resolution: 17" LCD 1280 x 1024**
- **Power Consumption: About 0.40 (KVA)**
- **Size / Weight: 2300mm (L) x 910mm (W) x 1320mm (H) / 410KG**
- **Working Temperature / Humidity: 0C ~ + 45C / 20% ~ 95% (None-condensing)**
- **Storage Temperature / Humidity: 40C ~ + 65C / 20% ~ 95% (None-condensing)**
- **Power Supply: AC 220 V (+10% ~ -15%) 50+3(Hz)**

### ■ Technical Drawing

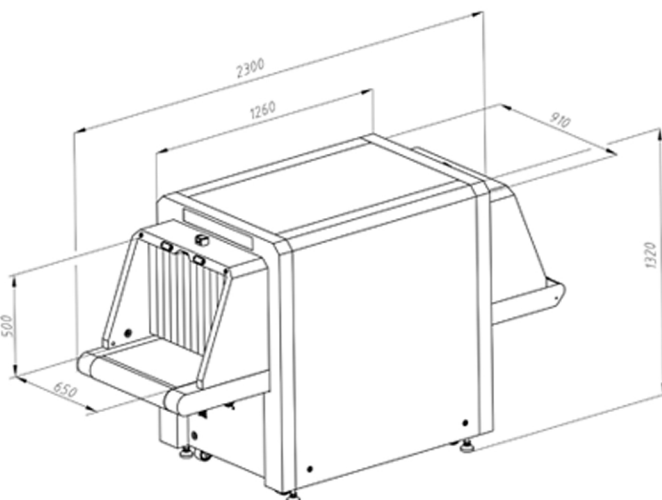

### ■ CONTACT US

@ info@akkula.co.uk

S Akkula Group

☎ +44 (0) 117 318 0845 - UK

☎ +1 (702) 509 - 7610 - Americas

Follow us on Social Media

