

150150 CARGO - Multi Energy X-ray Security Inspection Equipment

■ Overview

The 150150 CARGO Multi Energy X-ray Security Inspection system is an intelligent safety inspection system which is able to detect Organic, Non-Organic, Mixtures and Light metals whilst maintaining a reasonable user friendly design to maintain a highly efficient operation. The 150150 CARGO has specially designed to meet the needs and applications of warehouses, Couriers and airports for the inspection of bulky parcels, heavy luggage and large goods

- **Tunnel Size: 1500mm (W) x 1505mm (H)**
- **Dimensions: 4350mm (L) x 2890 mm (W) x 2070 mm (H)**

■ Features

- Portable separate structural design, with independent operator desk
- Side X-ray generator installed, lower X-ray energy attenuation, clearer image
- Built-in various image processing algorithms, multiple image transformation
- EI-TIP(Threat Image Projection) function
- Built-in auto self-diagnostic capability, Monitors and reports problems
- Big Tunnel design with multi-functions operator interface
- Operation log recording, providing complete information for rapid diagnosis and maintenance



■ Specifications

- **Tunnel Size: 1500mm (W) x 1500mm (H)**
- **Conveyor Height: 350mm**
- **Conveyor Speed: 0.2m/s**
- **Max Load: 2000kg (Evenly distributed)**
- **System Noise: <65dB (A)**
- **Image Resolution: 22" LCD 1920 x 1080**
- **Power Consumption: About 0.46 (KVA)**
- **Size / Weight: 4350mm (L) x 3890mm (W) x 2070mm (H) /2000KG**
- **Working Temperature / Humidity: 0C ~ + 45C / 20% ~ 95% (None-condensing)**
- **Storage Temperature / Humidity: 40C ~ + 60C / 20% ~ 95% (None-condensing)**
- **Power Supply: AC 220 V (+10% ~ -15%) 50+3(Hz)**

■ Technical Drawing

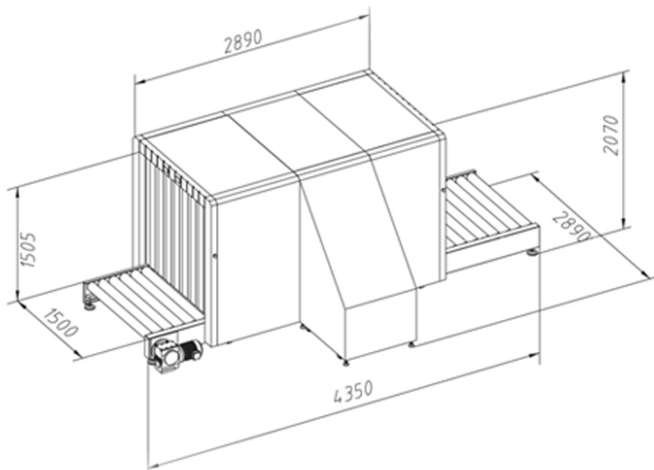

■ CONTACT US

- @ info@akkula.co.uk
- S Akkula Group**
- +44 (0) 117 318 0845 - UK**
- +1 (702) 509 - 7610 - Americas**

Follow us on Social Media

