

## 100100 CARGO - Multi Energy X-ray Security Inspection Equipment

### ■ Overview

The 100100 CARGO Multi Energy X-ray Security Inspection system is an intelligent safety inspection system which is able to detect Organic, Non- Organic, Mixtures and Light metals whilst maintaining a reasonable user friendly design to maintain a highly efficient operation. The 100100 CARGO is a very popular product among customs facilities, transportation operations, parcel services, asset protection and airports.

- **Tunnel Size: 1010mm (W) x 1010mm (H)**
- **Dimensions: 3396mm (L) x 1330 mm (W)x 2145 mm (H)**

### ■ Features

- **Portable separate structural design, with independent operator desk**
- **High-precision X-ray detectors, making images sharp and clear**
- **Multi-functions image processing system**
- **EI-TIP( Threat Image Projection) function**
- **Collects high-speed parallel of detection data**
- **Big Tunnel design with multi-functions operator interface**
- **Support JPG & BMP image transformation format to USB**



### ■ Specifications

- **Tunnel Size: 1010mm (W) x 1010mm (H)**
- **Conveyor Height: 350mm**
- **Conveyor Speed: 0.2m/s**
- **Max Load: 2000kg ( Evenly distributed)**
- **System Noise: <65dB (A)**
- **Image Resolution: 22" LCD 1920 x 1080**
- **Power Consumption: About 0.46 (KVA)**
- **Size / Weight: 3396mm (L) x 1330mm (W) x 2145mm (H) /2000KG**
- **Working Temperature / Humidity: 0C ~ + 45C / 20% ~ 95% (None-condensing)**
- **Storage Temperature / Humidity: 40C ~ + 60C / 20% ~ 95% (None-condensing)**
- **Power Supply: AC 220 V (+10% ~ -15%) 50+3(Hz)**

### ■ Technical Drawing

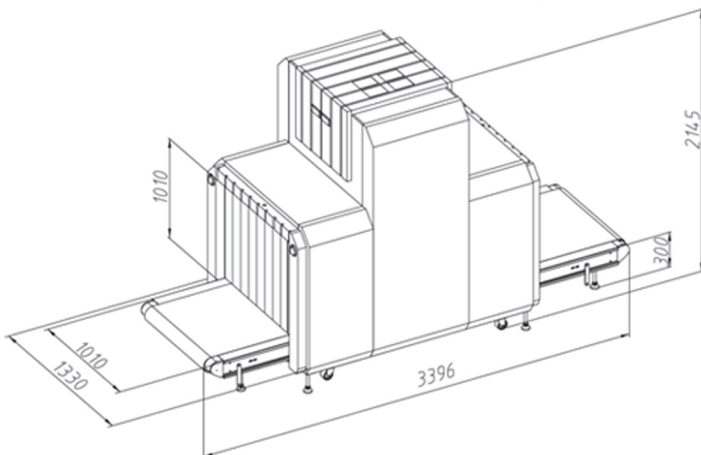

### ■ CONTACT US

@ info@akkula.co.uk

S Akkula Group

+44 (0) 117 318 0845 - UK

+1 (702) 509 - 7610 - Americas

Follow us on Social Media

